

The Robotic Seabed Cleaning Platform: An Underwater Cable-Driven Parallel Robot for Marine Litter Removal

Marc Gouttefarde¹, Mariola Rodriguez², Cyril Barrelet¹, Pierre-Elie Hervé², Vincent Creuze¹, Jose Gorrotxategi², Arkaitz Oyarzabal², David Culla², Damien Sallé², Olivier Tempier¹, Nicola Ferrari³, Marc Chaumont¹, and Gérard Subsol¹

¹ LIRMM, Univ Montpellier, CNRS, Montpellier, France
marc.gouttefarde@lirmm.fr

² TECNALIA, Basque Research and Technology Alliance (BRTA)
³ Servizi Tecnizi Srl, Italy

Abstract. As a contribution to the development of new techniques to remove marine litter from the seabed of seas and oceans, the Robotic Seabed Cleaning Platform has been designed, built and experimented in the framework of the European Union project MAELSTROM. It essentially consists of a floating platform that supports the base elements of a 6 degree-of-freedom cable-driven parallel robot actuated by eight winches. The mobile platform of this robot can work underwater and is equipped with sensors to control its underwater motions and to detect & identify marine litter. To achieve efficient and selective litter removal, an aspiration system and a gripper are installed on the CDPR underwater mobile platform.

Keywords: Marine litter, underwater robots, cable-driven parallel robots.

1 Introduction

It is estimated that about 70% of marine debris sinks to the seabed where it will fragment in micro and nano plastics. On overall, tens of million tons of waste and debris are estimated to lie on the seafloors of seas and oceans worldwide. Significant efforts to reduce sea and ocean pollution are thus of fundamental importance. Besides, developing new techniques for the removal of marine litter is needed. In this context, the European Union project MAELSTROM [1] aims at designing and integrating technologies to identify, remove, sort and transform all types of collected marine litter into valuable raw materials. In this project, two systems are considered for marine litter removal. The first one is developed by The Great Bubble Barrier and consists in catching plastic pollution in rivers before it reaches the ocean, using bubbles. The second one is presented in the present paper: The Robotic Seabed Cleaning Platform. It mainly consists of a floating platform that supports the base elements of a 6-DOF Cable-Driven

Parallel Robot (CDPR) actuated by eight winches. The mobile platform of this CDPR can work underwater and is equipped with sensors to control the underwater mobile platform motion and detect & identify marine litter to be removed. To achieve efficient and selective removal, an aspiration system to suck up smaller litter and a gripper to grasp and remove larger items, e.g. tires, are also installed on the CDPR underwater mobile platform.

Existing solutions for removal of marine litter lying on the seabed can be highly harmful to the marine ecosystem, e.g., dredges and bottom trawl nets. Human divers can also remove litter from the seabed but this work can put them in danger and their actions are limited in time and litter weight. Another option for marine litter removal is to use robotic systems. For instance, there exist autonomous surface vehicles to remove floating pollution such as the low cost, zero greenhouse emissions WaterShark [4] and the multi-purpose Jellyfishbot [3]. Besides, to remove litter from the seabed, underwater robots [5] can be used. Both autonomous underwater vehicles and Remotely Operated Vehicles (ROV) allow to reach seabed at depth of several tens or hundreds of meters. For example, the SeaClear project [2] aims at deploying a system consisting of an unmanned surface vehicle, an unmanned aerial vehicle, a small ROV and a larger ROV. The unmanned surface vehicle is the mothership that deploys the aerial vehicle and the two underwater robots. The aerial vehicle can search litter from the air (in clear water) and helps the navigation of the surface vehicle while the small ROV scan the seabed at close range. The larger ROV removes litter with a gripper and suction device. The SeaClear system should thus be able to operate autonomously over large distances but can remove rather small lightweight objects from the seafloor. Moreover, ROV may take time to stabilize before being able to grasp a litter, thus impairing efficiency. Hence, one advantage of the Robotic Seabed Cleaning Platform introduced in this paper is its capability to efficiently and selectively remove relatively large and heavy objects, as well as smaller ones, since it is based on a CDPR which constitutes a (relatively) accurate and fast positioning system.

Numerous previous papers on underwater cables exist in the literature, from their physical modeling, e.g. [6, 7], to their use as ROV umbilical, e.g., [13, 15], where the cables are usually used in low tension contrary to the case of CDPRs where tensed cables transmit motion and force. In fact, few previous works deal with marine and underwater CDPRs. In [9], the idea of a 6-DOF underwater mobile platform connected to surface ships by more than 6 cables is presented but there is no specific underwater modeling, design, control or experiments introduced in this paper. In [11, 12], the workspace, dynamic performances and various cable configurations of a Gough-Stewart type floating cable-driven marine platform subjected to waves are studied. The winches are placed on the surface mobile platform and the cables anchored on the seabed (mooring cables). Computer simulations are reported but no prototype and experiments are presented. Moreover, the concept of underwater robot actuated in a hybrid fashion by thrusters and cables is introduced in [8] and further studied in numerical

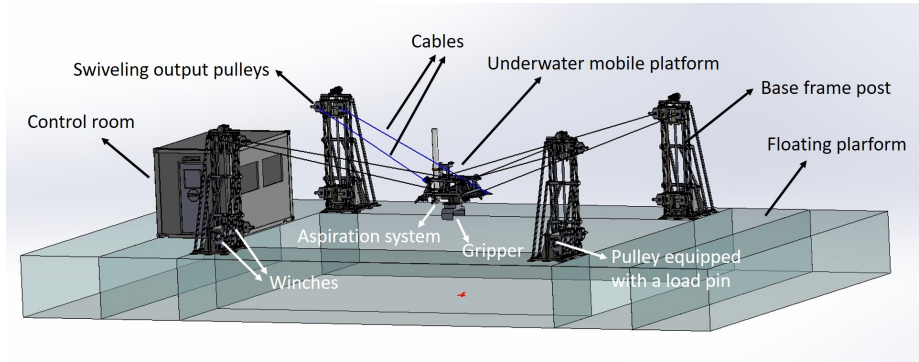

Fig. 1. The main components of the RSCP.

simulations in [14], but no experiment or prototype has been presented at the time of writing the present paper.

Hence, the contribution of this paper is to introduce the Robotic Seabed Cleaning Platform (RSCP) design, control and experimental testing to remove marine litter lying on the seabed of Venice lagoon. To the best of the authors' knowledge, it is the first time an underwater CDPR is designed and used. The paper is organized as follows. In Section 2, an overview of the RSCP is presented. Then, in Sections 3 and 4, the RSCP design and control are described, respectively. Finally, Section 5 presents the results of the first RSCP cleaning campaign in Venice lagoon while Section 6 concludes the paper.

2 Presentation of the Robotic Seabed Cleaning Platform

The RSCP consists mainly of a CDPR installed and operated from a floating barge. The mobile platform of the CDPR can work underwater and is equipped with selective cleaning tools that allow the removal of legacy small (micro-plastics > 5 mm) and large items on the seabed, as well as floating plastics in the water column, in a beneficial way for the marine ecosystem. The main components of the RSCP are presented in Fig. 1 where the mobile platform is shown outside of the water. In the CAD view of Fig. 2, the mobile platform is shown working underwater. The 6-DOF mobile platform of the RSCP is driven by eight cables in a suspended configuration similar to the one of the CoGiRo CDPR [10]. Four base frame posts are secured to the floating platform (floating barge), the latter being made of several modules (pontoons) assembled together. Each post has two winches and pulleys that route the cable from the winch to the top of the post where a swiveling output pulley directs the cable toward the mobile platform. One of the pulley located near the winch at the bottom of the post is equipped with a load pin and thereby allows the measurement of the cable tension. The mobile platform can move down in the water below the floating barge which has a rectangular hole (inner pool) in its middle. An aspiration system to suck

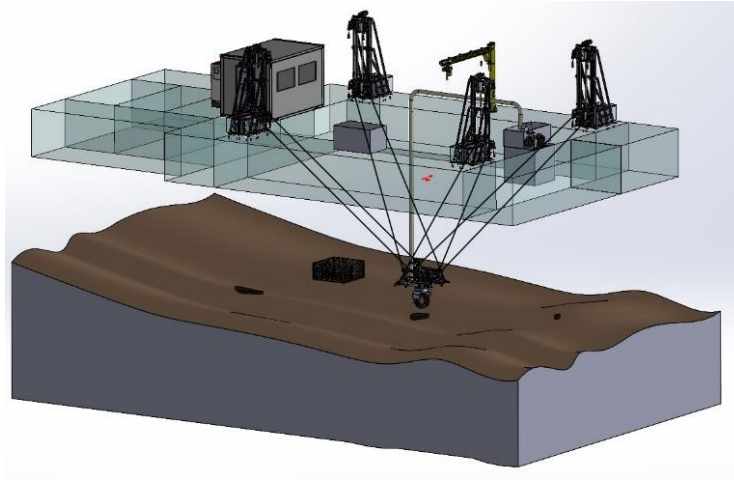

Fig. 2. A CAD view of the RSCP with the CDPR mobile platform working underwater.

up smaller litter in the water column and seabed below the hole in the floating barge, as well as a gripper to remove larger items, are installed on the CDPR underwater mobile platform. A control room hosts the electronic and control cabinets, the control PCs and the human operator(s) of the RSCP.

A picture of the RSCP during first tests on the ground in Tecnia's facilities in Spain is shown in Fig. 3. The mobile platform is the beige structure in the middle of the picture. After its setting up in Tecnia's facilities, the RSCP was disassembled and moved to Venice in Italy for its first underwater cleaning campaign (cf Section 5), as shown in Fig. 4.

3 Design of the Robotic Seabed Cleaning Platform

The RSCP components have been designed to be used in a harsh outdoor maritime environment. The maximum depth of operation of the underwater mobile platform is directly correlated to the size of the floating barge. Besides, the rigidity of the barge depends on the size of its inner pool. A compromise has been found in the design of the floating barge to reach the required depth of operation (between 15 to 20 m) while maximizing its rigidity. The CAD of the floating barge final design is shown in Fig. 5.

The floating barge, designed for both still waters and sea operations, is composed of several pontoons. Two metallic posts are fixed on two steel bases located on the same pontoon to avoid relative displacements between the swiveling output pulleys of the CDPR. The two other posts are also mounted on another single pontoon. During the experiments reported in Section 5, the relative displacement between two opposite posts mounted on different pontoons has been estimated by means of measurements with a total station. When middle size

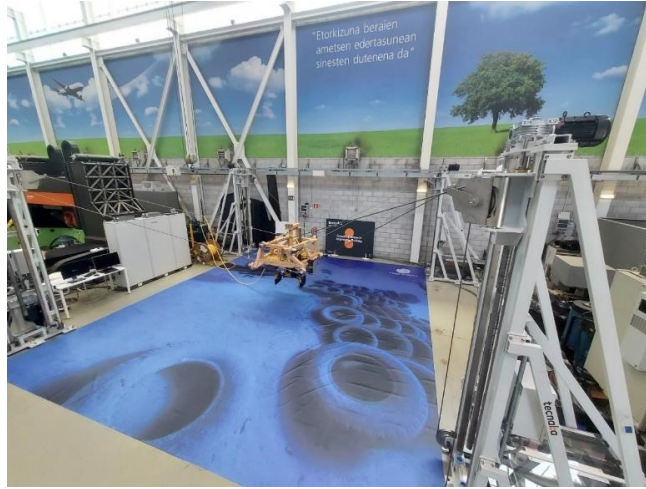

Fig. 3. The RSCP during tests in Tecnia's facilities.

waves are shaking the floating barge, the relative movement is around ± 5 mm, which was deemed to be an acceptable value. The floating barge is maintained in position, depending on the depth of the cleaning, by anchor feet or wire anchors to the seafloor. The floating barge is displaced from a cleaning spot to another one by a tugboat.

As shown in Fig. 6, each cable goes out of the winch and is guided by pulleys to a movable carriage. This carriage has a vertical translation to move the upper swiveling pulleys from a the lower position to an upper position, the latter being 2.5 m higher than the former. On the one hand, when the carriage is at the top of the post (parking position), this reconfiguration capability allows the CDPR mobile platform to be out of the water for assembly and maintenance operations and for moving the floating barge from spot to spot. On the other hand, when the carriage is at the bottom of the post (working position), it allows having the robot inside the water for marine litter removal operations with increased operational workspace. The marine litter removal operations are also possible in parking position, but the CDPR workspace size is reduced. The design of the supporting structure of the winches and pulleys is suitable for any kind of pontoons and floating barge and is independent of the height of the pontoon. The location of the posts on the floating barge has been defined by optimizing the workspace of the CDPR with methods well known in the state of the art.

The calibration of the positions of the swiveling pulleys (points A_i) is made with the help of a total station that measures reflective targets closed to the pulleys as shown in Fig. 7. For practical reasons, it is not possible to measure directly the positions of the cable-platform connection points B_i as they are virtual points at the center of rotation of universal joints. Hence, as shown in Fig. 8, a 3D printed plastic part installed around point B_i is used to measure



Fig. 4. The RSCP in Venice lagoon.

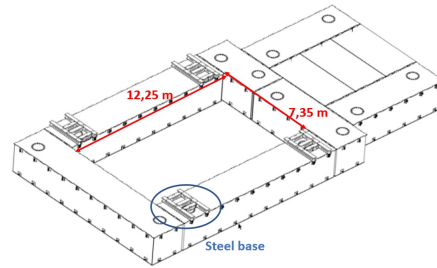

Fig. 5. CAD of the final design of the floating barge.

2 reflective targets. The position of point B_i is at the middle of the measured targets. The plastic part is removed from point B_i once it has been measured and installed to the next point B_i . Besides, three reflective targets are fixed on the mobile platform to measure its pose. The positions of these targets are measured just before or after the position measurements of the points B_i . This platform pose measurement is required to calibrate the initial pose of the platform.

The underwater mobile platform, shown in Fig. 9, is a classic steel welded structure, protected by a marine resistant paint. The cable attachment points (points B_i) are made with stainless steel universal joints. All bearings at points A_i and B_i are Igus plastic bearings to avoid corrosion. The cables are non-rotating steel wires of diameter 12 mm. They are generously greased with a bio sea water compatible grease, to prevent corrosion.

4 Sensors and control system

Various sensors are located on the floating floating barge including a pressure sensor to compensate for the atmospheric pressure and two RTK GPS placed at two

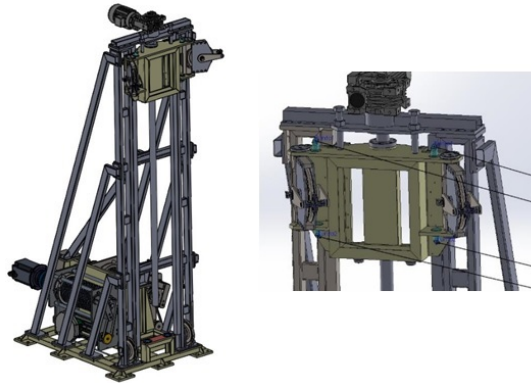

Fig. 6. Final CAD design of the metallic posts (left subfigure) and the swiveling output pulleys (right subfigure).

different locations on the floating barge to estimate the position and orientation (around the vertical axis) of the floating barge based on position measurements from a global navigation satellite system. It thus allows to position the RSCP on top of a previously generated bathymetry map of the seabed environment, allowing to identify "hotspots", to position the barge inner pool above one of these hotspots and to make the CDPR mobile platform dive to reach it. This capability turned out to be a key enabling feature in the highly turbid water of Venice lagoon. Moreover, the CDPR has eight force sensors placed at fixed (non swiveling) routing pulleys to measure the cable tensions as well as encoders in the winch motors.

The sensors located inside the underwater platform shown in Fig. 9 comprise five IP cameras which enable the human operator located in the control room on the floating barge to see the surrounding of the underwater platform (provided that water turbidity is not too high). Several other sensors, listed below, are also integrated into the so-called "smart camera" system, shown in Fig. 10, which is fixed to the mobile platform on one of its edge. The smart camera mainly consists of the following components. A camera used for visual servoing: The camera enables a marine litter to be seen by the operator who can click on the litter in the camera image so that the CDPR mobile platform approaches the litter automatically. One depth (pressure) sensor to measure the depth of the mobile platform (distance with respect to the sea surface). One IMU used mainly to measure the orientation of the underwater mobile platform. A Doppler Velocity Log (DVL) which is a hydro-acoustic sensor integrating four acoustic beams to measure the distance of the mobile platform to the seabed and its velocity with respect to the seabed. The DVL estimates velocity relative to the sea bottom by sending acoustic waves from four angled transducers and then measure the frequency shift (Dopplers effect) from the received echo. By combining the measurements of all four transducers and the time between each

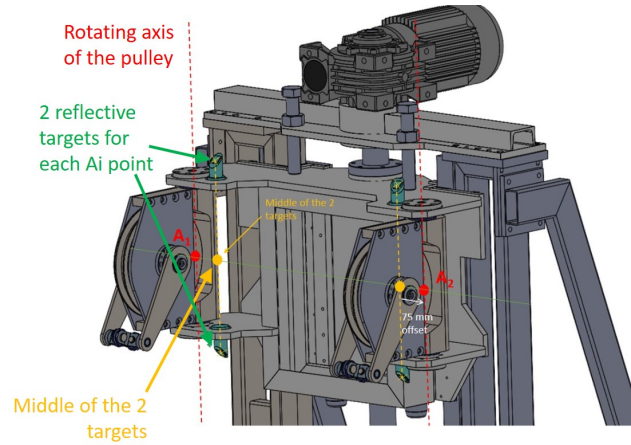

Fig. 7. Calibration: Determination of the positions of the points A_i from the target measurements.

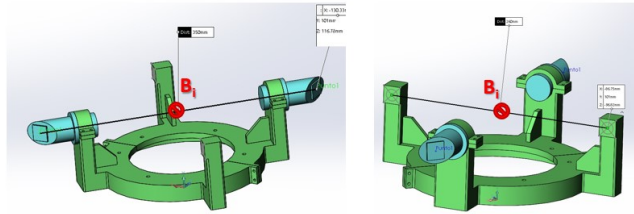

Fig. 8. Calibration: 3D plastic parts used to measure the positions of points B_i .

acoustic pulse, it is possible to estimate the speed and direction of movement. Since the DVL also indicates the altitude with respect to the seabed (from the range measurements achieved by the four beams), it can be used to build a local map of the seabed slope (sea ground surface) such as illustrated in Fig. 12. To this end, the pressure sensors on the floating barge and on the underwater mobile platform are also used to determine the depth of the mobile platform with respect to the floating barge and the altitude of the floating barge with respect to the seabed. Subsequently, the two GPS on the floating barge can be used to locate the local map in a global earth coordinate system. This allows either estimating previously located underwater litter positions and/or to build a map of the (removed) litters.

The control system of the CDPR of the RSCP used in the experiments reported in Section 5 consists of the CDPR teleoperation control and the perception system for underwater vision. Regarding the CDPR teleoperation control, the pilot (human operator) uses estimated underwater mobile platform pose as well as the cameras located on the mobile platform to drive the underwater mobile platform using a joystick. The joystick commands issued by the pilot are

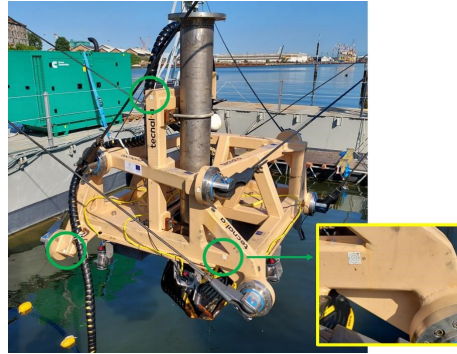

Fig. 9. Close-up view of the underwater mobile platform including 3 reference points on the platform (reflective targets).

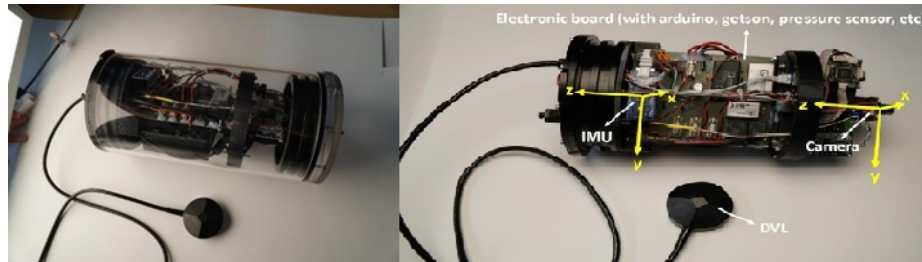

Fig. 10. The waterproof underwater capsule of the smart camera system (left) and the smart camera system description with reference frames fixed to it (right).

interpreted as desired operational velocities, i.e., linear and angular velocities of the underwater mobile platform. These velocities are integrated to provide desired positions and orientations of the mobile platform that are converted into desired winch motor positions by means of the inverse kinematics of the CDPR. These desired joint motor positions are sent on the fly to the drive setpoint controllers which are in charge of the feedback position control of the motors. The Human-Machine Interface (HMI) of the CDPR is shown in Fig 11. It allows the human operator (pilot) to monitor various sensor values and to choose between different control modes. The human operator can see the videos from the IP cameras placed on-board the underwater mobile platform in a dedicated screen.

Regarding the perception system for underwater vision, the camera in the smart camera system is used as the underwater perception system. It notably enables visual servoing: Once a marine litter is seen by the human operator (at relatively closed range from the camera because of water turbidity), the latter can click on the litter in the camera image and the CDPR mobile platform approaches the litter automatically. Figure 12 shows the HMI of the underwater perception system. On the left, the depth map built with the DVL measurement is shown. In the middle, the human operator can see the image from the camera



Fig. 11. HMI of the CDPR: 1. Winch axis information area; 2. Secondary commands for individual or combined motion of the cables, motion command to calibration position, and enabling post vertical carriage linear movements using the joystick; 3. Mobile platform position and orientation information area; 4. Manual commands area including initialization (calculation of the Cartesian pose computed using the winch motor positions by means of forward kinematics), manual move with joystick enabling & speed override setting, and robot status; 5. Automatic command area including point-to-point motion command (actual to destination pose) and CNC trajectory program execution; 6. Cable tension monitoring area: Force sensor values in Kg.

of the smart camera system (here shown in turbid water with very little visibility range). The operator can click on a point in this image, where a possible litter to be removed is located, so that the mobile platform moves toward this point. On the right of the HMI, the bathymetry map is shown. It is centered on the RSCP inner pool (the orange rectangle). The red rectangle is the safe working zone where no collision between the RSCP and the CDPR cables can happen. In the HMI bottom part, various sensor values and other information are displayed.

5 Experiments in Venice

The RSCP was tested in September 2022 in Venice lagoon in Italy where it performed a cleaning campaign. Despite highly turbid water, the cleaning campaign was a success since many marine litters of several different types were removed from the seabed, as shown in Fig. 13. To deal with the very low visibility due to the turbidity of the lagoon water, real-time image enhancement was used to improve the perception of the marine litter with the cameras on-board the CDPR underwater mobile platform.⁴

⁴ As shown in the following videos of the RSCP experiments in Venice: <https://youtu.be/1EVQm-0yyRY> and <https://youtu.be/16k3-Bp4FCI>

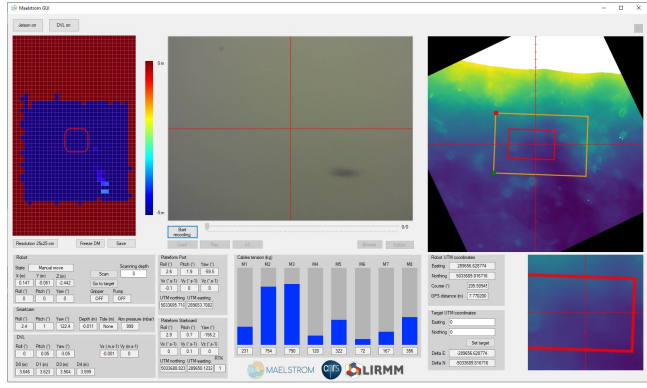

Fig. 12. HMI of the underwater perception system.

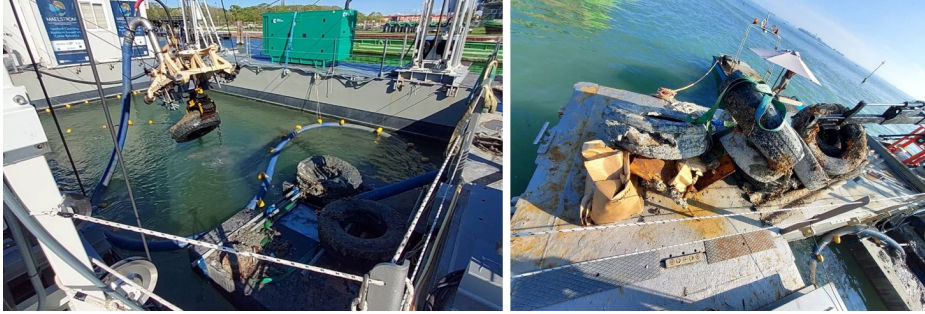

Fig. 13. The RSCP removing a tire from the water (left) and various litters collected by the RSCP during the cleaning campaign in Venice lagoon.

6 Conclusion

This paper presented the Robotic Seabed Cleaning Platform. It mainly consists of a floating platform that supports the base elements of a 6-DOF CDPR actuated by eight winches. The mobile platform of this CDPR can work underwater and is equipped with sensors to control the underwater mobile platform motion and detect & identify marine litter to be removed. To achieve efficient and selective removal, an aspiration system to suck up smaller litter and a gripper to grasp and remove larger items, e.g. tires, are also installed on the CDPR underwater mobile platform. To the best of the authors’ knowledge, it is the first time an underwater CDPR is designed and used. The Robotic Seabed Cleaning Platform was successfully experimented in Venice lagoon where many marine litters of several different types were removed from the seabed.

7 Acknowledgments

This work was supported by the European Union’s H2020 Program (H2020-FNR-2020) under the grant agreement No. 101000832 (MAELSTROM project).

References

1. European union’s H2020 project MAELSTROM. <https://www.maelstrom-h2020.eu> (2023)
2. European union’s H2020 project SeaClear. <https://seaclear-project.eu/> (2023)
3. Jellyfishbot: Surface robot for the cleaning and the depollution of water surfaces. <https://www.jellyfishbot.io/> (2023)
4. Wasteshark: Autonomous surface vessel designed by RanMarine. <https://www.ranmarine.io/products/wasteshark-3/> (2023)
5. Antonelli, G.: Underwater Robots: Motion and Force Control of Vehicle-Manipulator Systems. In: Springer Tracts in Advanced Robotics. Second edition, Springer (2006)
6. Boyer, F., Nayer, G., Leroyer, A., Visonneau, M.: Geometrically exact kirchhoff beam theory: Application to cable dynamics. *ASME Journal of Computational and Nonlinear Dynamics* **6** (Oct 2011)
7. Buckham, B., Nahon, M.: Formulation and validation of a lumped mass model for low-tension rov tethers. *International Journal of Offshore and Polar Engineering* **11**(4), 282–289 (2001)
8. El Ghazaly, G., Gouttefarde, M., Creuze, V.: Hybrid cable-thruster actuated underwater vehicle manipulator systems: A study on force capabilities. In: Proc. IEEE/RSJ Int. Conf. Intelligent Robots and Systems (IROS). Hamburg, Germany (2015)
9. Ghaffar, A., Hassan, M.: Study on cable based parallel manipulator systems for subsea applications. In: Proc. 3rd International Conference on Mechanical Engineering and Mechatronics. Prague, Czech Republic (2014)
10. Gouttefarde, M., Collard, J.F., Riehl, N., Baradat, C.: Geometry selection of a redundantly actuated cable-suspended parallel robot. *IEEE Trans. on Robotics* **31**(2), 501–510 (2015)
11. Horoub, M., Hassan, M., Hawwa, M.: Workspace analysis of a gough-stewart type cable marine platform subjected to harmonic water waves. *Mechanism and Machine Theory* **120**, 314325 (2018)
12. Horoub, M., Hawwa, M.: Influence of cables layout on the dynamic workspace of a six-dof parallel marine manipulator. *Mechanism and Machine Theory* **129**, 191201 (2018)
13. Laranjeira, M., Dune, C., Hugel, V.: Catenary-based visual servoing for tether shape control between underwater vehicles. *Ocean Engineering* **200** (2020)
14. Sacchi, N., Simetti, E., Antonelli, G., Indiveri, G., Creuze, V., Gouttefarde, M.: Analysis of hybrid cable-thruster actuated rov in heavy lifting interventions. In: Proc. IEEE/RSJ International Conference on Intelligent Robots and Systems (IROS). Kyoto, Japan (2022)
15. Viel, C.: Self-management of the umbilical of a ROV for underwater exploration. *Ocean Engineering* **248** (2022)